

We perform under high pressure.

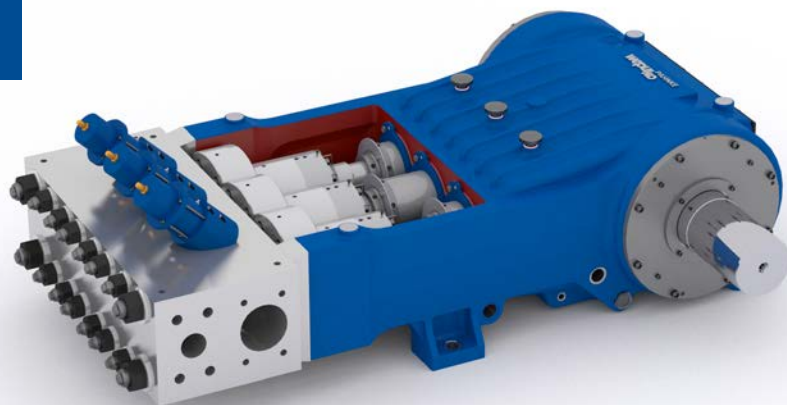

Highlights:

- Energy efficient
- Easy maintenance
- Extremely compact
- Energy efficient
- Extensive accessories, such as our pneumatic intake valve boost (PSVA)
- Low noise

DP 405 | Technical data

High-pressure triplex plunger pump

Nominal pressure (bar)	Plunger diameter (mm)	Effective volume flow (l / min)										
		13	15	16	19	21	22	26	30	33	37	
1000	20	13	15	16	19	21	22	26	30	33	37	
800	22	16	18	20	22	25	27	31	36	40	44	
630	44	22	25	28	32	36	38	44	51	57	63	
500	28	26	29	33	37	42	44	52	59	66	73	
400	32	34	38	43	48	54	57	67	78	86	95	
315	36	44	49	54	61	69	73	86	99	110	121	
250	40	54	60	67	76	86	91	106	123	135	150	
200	45	68	76	85	96	109	115	134	155	171	190	
160	50	84	94	105	118	134	141	166	192	212	234	
125	55	102	113	127	143	162	171	201	232	256	283	
Pump speed (min ⁻¹)		236	263	295	332	376	397	466	538	594	657	
Shaft power (kW)		25	28	32	36	41	43	50	58	64	71	
Attachement Gear						X	X	X	X	X		

The specified values are based on continuous operation and using water as a working medium.

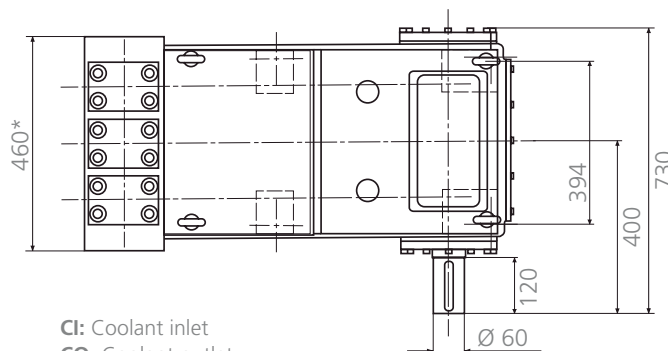
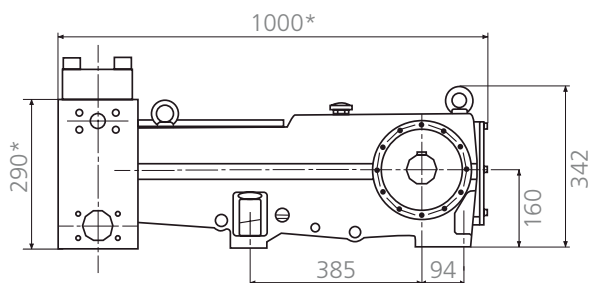

CI: Coolant inlet
CO: Coolant outlet
B: 4x fixing hole dia. 17 mm

Definition Attachement Gear

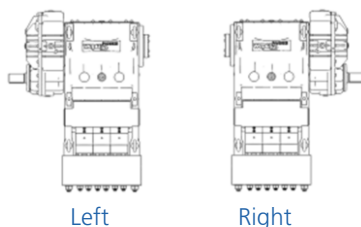

Version with integrated water cooling
Weight: approx. 870 kg

All dimensions specified in mm.

Application examples

- Hydraulic drives
- Descaling
- Industrial cleaning
- Deburring
- Hydroentanglement
- And many more applications

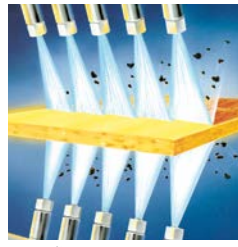

Descaling



Forging press drives

Is your application not mentioned here?

Please give us a call. We'll be pleased to advise you.

Design features

- Extremely compact design
- Robust construction suitable for continuous and intermittent operation
- Easily accessible valve inserts
- Excellent suction capacity
- Plungers made of coated stainless steel, ceramic or other high-grade materials
- Low-maintenance drive unit
- Start-up under load possible
- Self-adjusting maintenance-free high-pressure seal
- Maintenance-free low-pressure seal
- Quick-release piston clamp for rapid assembly and maintenance

Accessories

- Pneumatic intake valve boost
- Safety valve
- Recirculating valve
- Pressure regulating valve
- Shut-off valve
- Check valve
- Pressure oil lubrication
- Pulsation damper
- Water or air cooling
- Sound insulation
- Filter units
- Pump controller
- System accessories
- Diagnostic aid
- Further accessories on request

Drive options

- Compact V-belt drive (vertical design)
- V-belt drive
- Gearbox with or without couplings
- Vertical gearbox
- Direct drive (with or without frequency converter)
- Attachment Gear



Wepuko PAHNKE GmbH
Max-Planck-Str. 10
72555 Metzingen
Germany

Tel.: +49 7123 1805-0
Fax: +49 7123 41231
wepuko@wepuko.de
www.wepuko.com

