



Highlights:

- Energy efficient
- Easy maintenance
- Extremely compact
- Energy efficient
- Extensive accessories, such as our pneumatic intake valve boost (PSVA)
- Low noise

DP 403 | Technical data

High-pressure triplex plunger pump

Nominal pressure (bar)	Plunger diameter (mm)	Effective volume flow (l / min)										
		4	5	6	6	7	8	9	10	11	12	
1000	14	4	5	6	6	7	8	9	10	11	12	
800	16	6	6	7	8	9	10	12	13	15	16	
630	18	7	8	9	10	12	13	15	17	19	21	
500	20	9	10	12	13	14	16	18	21	23	26	
400	22	11	12	14	16	17	19	22	25	28	31	
315	26	15	18	20	22	25	28	31	35	39	44	
250	28	18	20	23	26	29	32	36	41	45	51	
200	32	23	27	30	33	37	42	48	53	59	66	
160	36	29	34	38	42	47	53	60	68	75	84	
125	40	36	41	47	52	58	65	74	83	93	104	
Pump speed (min ⁻¹)		286	327	368	411	461	514	586	659	732	820	
Shaft power (kW)		9	10	11	12	14	15	17	20	22	25	

The specified values are based on continuous operation and using water as a working medium.

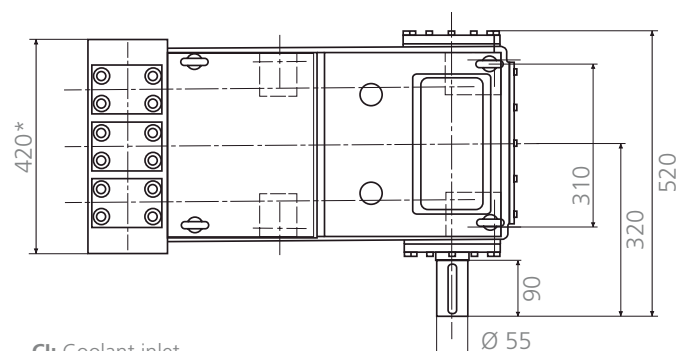
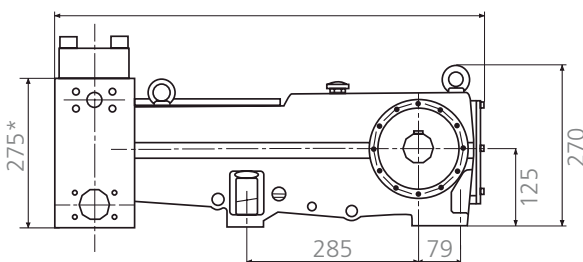

CI: Coolant inlet
CO: Coolant outlet
B: 4x fixing hole dia. 17 mm

Version with integrated water cooling
Weight: approx. 260 kg

All dimensions specified in mm.

Application examples

- Hydraulic drives
- Descaling
- Industrial cleaning
- Deburring
- Hydroentanglement
- And many more applications



Descaling



Forging press drives

Is your application not mentioned here?

Please give us a call. We'll be pleased to advise you.

Design features

- Extremely compact design
- Robust construction suitable for continuous and intermittent operation
- Easily accessible valve inserts
- Excellent suction capacity
- Plungers made of coated stainless steel, ceramic or other high-grade materials
- Low-maintenance drive unit
- Start-up under load possible
- Self-adjusting maintenance-free high-pressure seal
- Maintenance-free low-pressure seal
- Quick-release piston clamp for rapid assembly and maintenance

Accessories

- Pneumatic intake valve boost
- Safety valve
- Recirculating valve
- Pressure regulating valve
- Shut-off valve
- Check valve
- Pressure oil lubrication
- Pulsation damper
- Water or air cooling
- Sound insulation
- Filter units
- Pump controller
- System accessories
- Diagnostic aid
- Further accessories on request

Drive options

- Compact V-belt drive (vertical design)
- V-belt drive
- Gearbox with or without couplings
- Vertical gearbox
- Direct drive (with or without frequency converter)



Wepuko PAHNKE GmbH
Max-Planck-Str. 10
72555 Metzingen
Germany

Tel.: +49 7123 1805-0
Fax: +49 7123 41231
wepuko@wepuko.de
www.wepuko.com

